

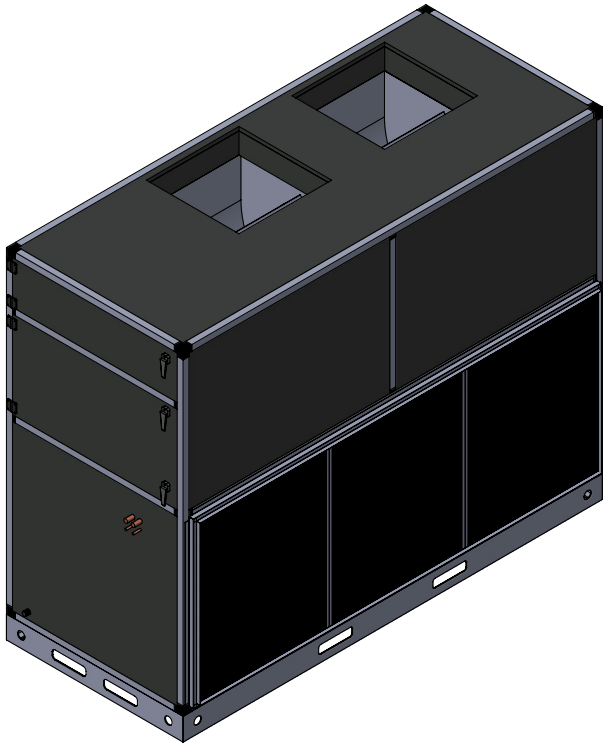

Commercial Manual
COSTERA Series
50 TON SPLIT SYSTEM

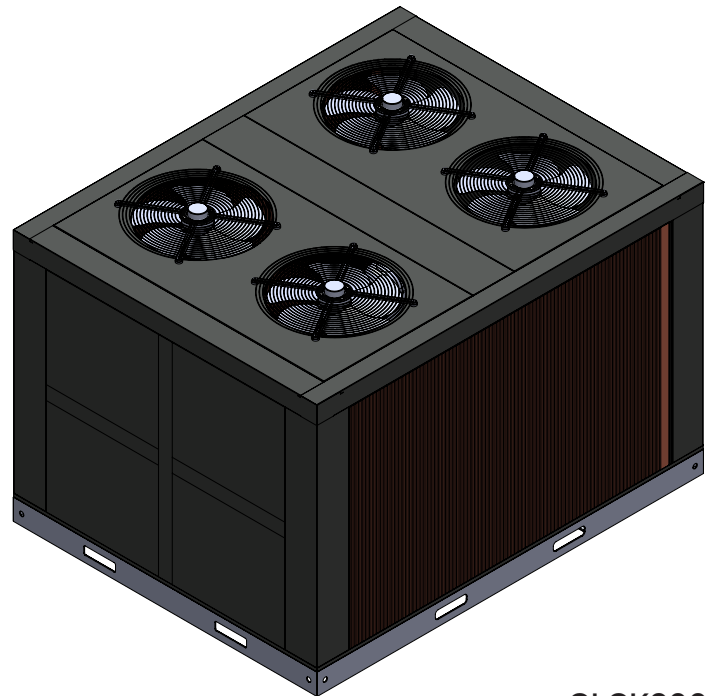

GXBK600



GLCK600

- Condenser Unit manufactured in large galvanized steel sheet. Air Handling Unit panels made of double-walled heavy-gauge galvanized steel with insulation.
- Powder coated paint system: For a long-lasting professional finish. Additional Modine-Luvata corrosion resistant spray added for extra protection.
- Copeland Scroll compressor, which offers greater protection against liquid damage. More efficient throughout its operational range; operates at lower sound and vibration levels than traditional compressors.
- Easy access to compressors.

- Serpentin evaporator and condenser made of copper tubes and copper fins.
- Certified electric motor (PSC motor).
- Compact unit of two cooling circuits.
- Air handling unit with 1" double wall.
- Fan motor coupling with pulley transmission.
- Thermo-acoustic insulation of expanded polyethylene.
- Evaporator fan compartment has easy access with hinged panels.
- Stainless steel rivet-nut machine-threaded hex head screw-fixed service panels.
- Reinforced iron metal base with forklift openings.

Table of Contents

- 3** Precautions
- 4** Technical Specifications
- 6** Blower Performance Data
- 7** Unit Dimensions
- 9** Safety Distance
- 10** Safe Handling
- 11** Electric Diagram
- 17** Suggestions for Installation
- 19** Suggestions for Ignition
- 20** Maintenance Recommendations
- 21** Notes

This document will provide relevant information about the equipment. All the information included in this manual is subject to changes without prior notice. The suggestions of this manual are addressed to the personnel in charge of planning, installing, implementing, and maintaining the equipment, having corresponding knowledge for the realization of these type of works.



WARNING

Installation, adjustment, alteration, service or maintenance can cause personal injuries, death, or property damage.

The installation and service must be carried out by a professional or equivalent professional installer or a service agency.



CAUTION

Physical contact with edges while applying excessive force or rapid movement with metal can cause personal injury. Be careful when working near these areas during installation or during the service of this equipment.

Precautions

In the following document you can find several useful suggestions on the ignition, use and maintenance of your air conditioning split system. Preventive care will help you save time and money during the useful life of the unit.

Precaution

- Contact an authorized technician in case of requiring the repair or maintenance of this unit.
- Contact an authorized installer to install this unit.
- In case of replacement of supply cables, this activity can only be carried out by authorized personnel.
- The installation must be carried out only by authorized personnel in accordance with wiring standards.
- The electrical installation must be carried out in accordance with current legal norms.
- Make sure the electric service is adequate for the selected equipment model.
- Make sure the equipment is correctly installed. To avoid electrical discharges and possible fires, the correct connection is important.
- If the voltage supplied to this equipment is outside the specified range, the equipment will not work and this can cause the main components of the equipment (compressors - motors) and other electrical components to burn out.
- Do not store or use gasoline or other flammable products near this equipment or other artifacts.

Incorrect manipulation due to lack of knowledge of the instructions or suggestions described in this manual can harm the unit. We do not assume any responsibility for damages derived from incorrect, inappropriate or not planned use, or to consequences of unauthorized repairs or modifications. Keep in mind that this document is only valid for the specified equipment and not for complete installation.

Technical Specifications

	GLCK600DG4AB	GLCK600DG7AB	GLCK600DG9AB
GENERAL DATA			
Cooling Capacity (BTU/h)	600,000	600,000	600,000
Cooling Tons	50	50	50
Efficiency ^[1] EER	11.8	11.8	11.8
CONDENSER FAN			
Number of Fans	4	4	4
Type	Axial	Axial	Axial
Number of Motors	4	4	4
Current (A)	6.4	3.7	3.7
Power (W)	1918	2143	1750
RPM	1057	1055	1070
Fan Diameter (mm)	800	800	800
CONDENSER COIL			
Type (Tube / Fin)	Copper / Copper	Copper / Copper	Copper / Copper
Area (ft ²)	80	80	80
Rows / Fins per Inch	3 / 13	3 / 13	3 / 13
Liquid Connection (Qty.)	5/8" (4)	5/8" (4)	5/8" (4)
Suction Connection (Qty.)	1 3/8" (4)	1 3/8" (4)	1 3/8" (4)
COMPRESSOR			
Refrigerant	R410a	R410a	R410a
Quantity	4	4	4
Type	Scroll	Scroll	Scroll
RLA ^[2]	48.1 / 53.6	18.6 / 20.7	23.7 / 26.4
LRA ^[3]	245.0	125.0	145.0
ELECTRICAL DATA			
V / Ph / Hz	(208-230 / 3 / 60)	(460 / 3 / 60)	(380 / 3 / 60)
Operating Current ^[1] (A)	240.0	98.0	120.0
Total Unit Amperage ^[1] (A)	240.0	98.0	120.0
Minimum Circuit Ampacity (A)	253.0	103.0	126.0
Max. Overload Protection (A)	307.0	214.0	153.0
NET WEIGHT (kg)	1288	1288	1288
GROSS WEIGHT (kg)	1308	1308	1308

Notes: ¹ Data corresponding to a certain operation condition based on the AHRI 210/240 or 360 standard. ² This Rated Load Amps data (RLA) corresponds to a single compressor. ³ This Locked Rotor Amps data (LRA) corresponds to a single compressor.

Technical Specifications

	GXBK600DG4BB	GXBK600DG7BB	GXBK600DG9BB
GENERAL DATA			
Cooling Capacity (BTU/h)	600,000	600,000	600,000
Cooling Tons	50	50	50
Efficiency ^[1] EER	11.8	11.8	11.8
EVAPORATOR FAN			
Transmission	Pulley	Pulley	Pulley
Type	Centrifugal	Centrifugal	Centrifugal
Fan Quantity	2	2	2
Nominal Air Flow ^[1] (CFM)	20000	20000	20000
Fan (DxW)	20 x 20	20 x 20	20 x 20
Motor Quantity	1	1	1
Current (A)	36	18.2	22.7
Power (HP)	15	15	15
RPM	1800	1800	1800
EVAPORATOR COIL			
Type (Tube / Fin)	Copper / Copper	Copper / Copper	Copper / Copper
Configuration	Slant	Slant	Slant
Area (ft ²)	40.1	40.1	40.1
Rows	3	3	3
Rows	13	13	13
Liquid Connection (Qty.)	5/8" (4)	5/8" (4)	5/8" (4)
Suction Connection (Qty.)	1 1/8" (4)	1 1/8" (4)	1 1/8" (4)
ELECTRICAL DATA			
V / Ph / Hz	(208-230 / 3 / 60)	(460 / 3 / 60)	(380 / 3 / 60)
Operating Current ^[1] (A)	36.0	18.2	22.7
Total Unit Amperage ^[1] (A)	36.0	18.2	22.7
Minimum Circuit Ampacity (A)	45.0	23.0	28.0
Max. Overload Protection (A)	81.0	41.0	52.0
AIR FILTRATION			
Quantity	3	3	3
Filter Size (mm)	1260 x 990 x 20	1260 x 990 x 20	1260 x 990 x 20
NET WEIGHT (kg)	1060	1060	1060
GROSS WEIGHT (kg)	1075	1075	1075

Notes: ¹ Data corresponding to a certain operation condition based on the AHRI 210/240 or 360 standard.

Blower Performance Data

Model 2A20-20H	Flow 20000 cfm	Pressure 2.00 in-wg	Temperature 70 °F	Altitude 0 ft	Density 0.075 lb/ft ³	Q Derate 0 cfm	P Derate 0.00 in-wg	Vav Set Point 0.00 in-wg
Fan Tag	Flow 20000 cfm	Pressure 2.00 in-wg	Power 11.26 hp	Static Efficiency 56.0 %	Total Efficiency 65.9 %	Speed 708 rpm	Outlet Velocity 2381 fpm	Efficiency Rating FEG71
	Impeller Dia 20.0 in	Outlet Area 8.40 ft ²	Max. Speed 1280 rpm	AMCA Class 0	Drive Belt Drive	Blades 37	P Volume 58.50 ft ³	TurnDown 100 %

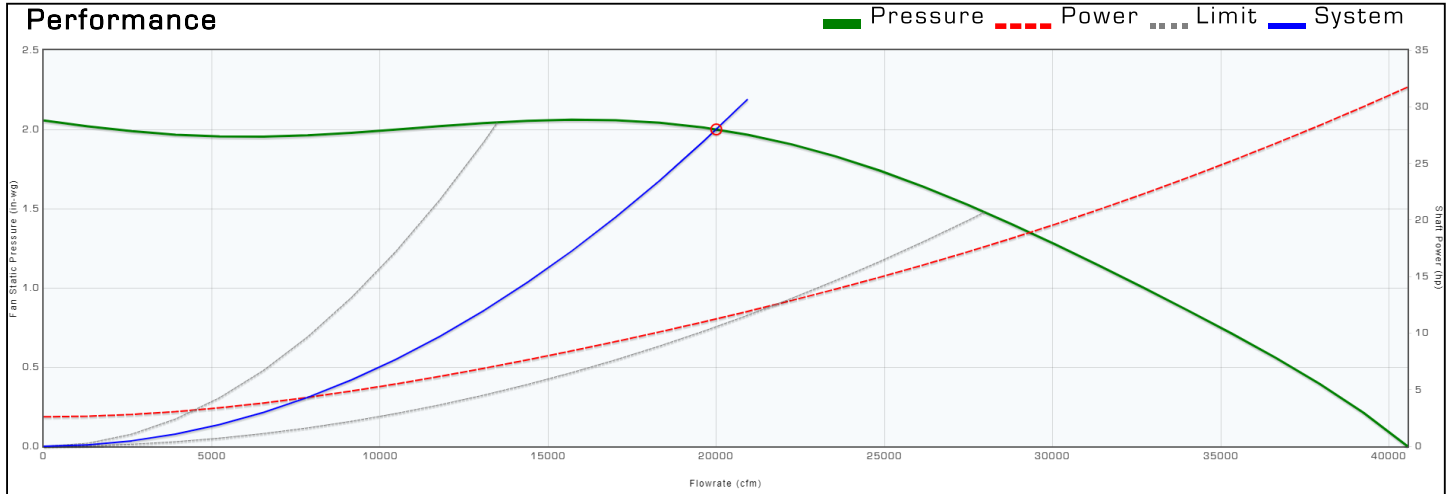

Sound(Lwi/Lwo)	63	125	250	500	1000	2000	4000	8000	Lw	LwA
	88/88	90/90	87/89	89/91	87/87	88/87	85/83	78/75	97/97	93/94

Notes: Airflow performance data are obtained in accordance with AMCA 210-07. Installed performance will vary depending on extent of cabinet geometry

Sound data are estimated from industry experience for the type of product selected. Data should be used for comparison purposes only and do not represent installed values.

Unit Dimensions

GLCK600

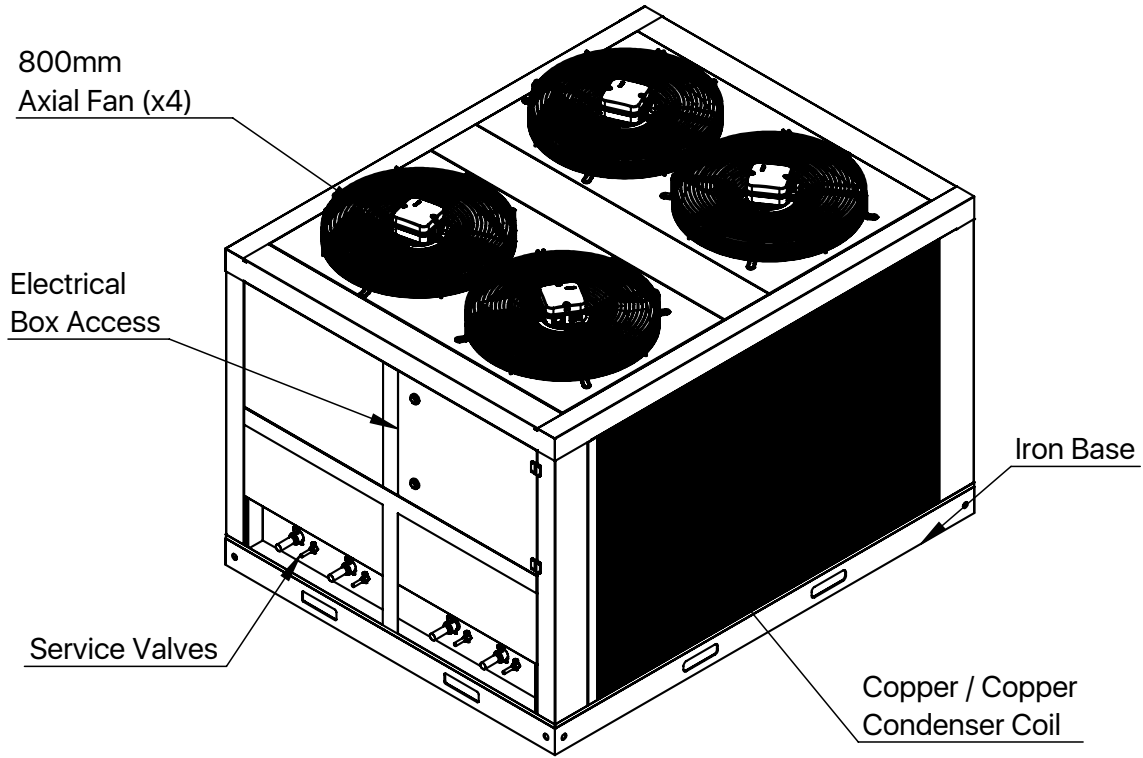

Top View

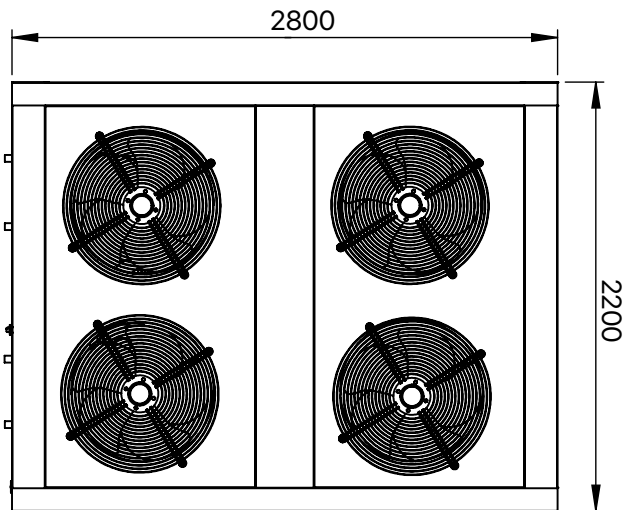

Side View

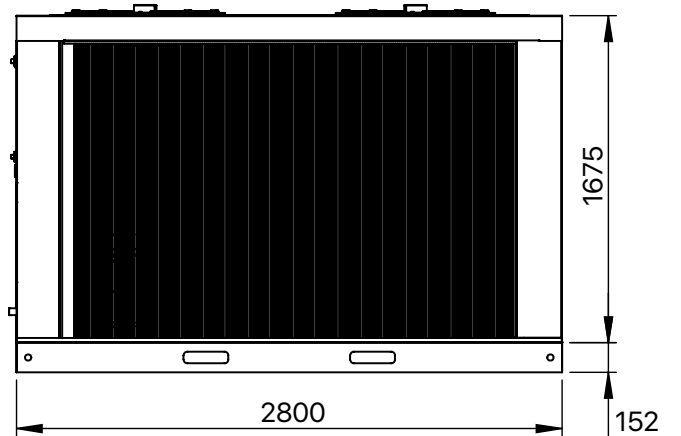

Note: All measurements are in millimeters (mm).

Unit Dimensions

GXBK600

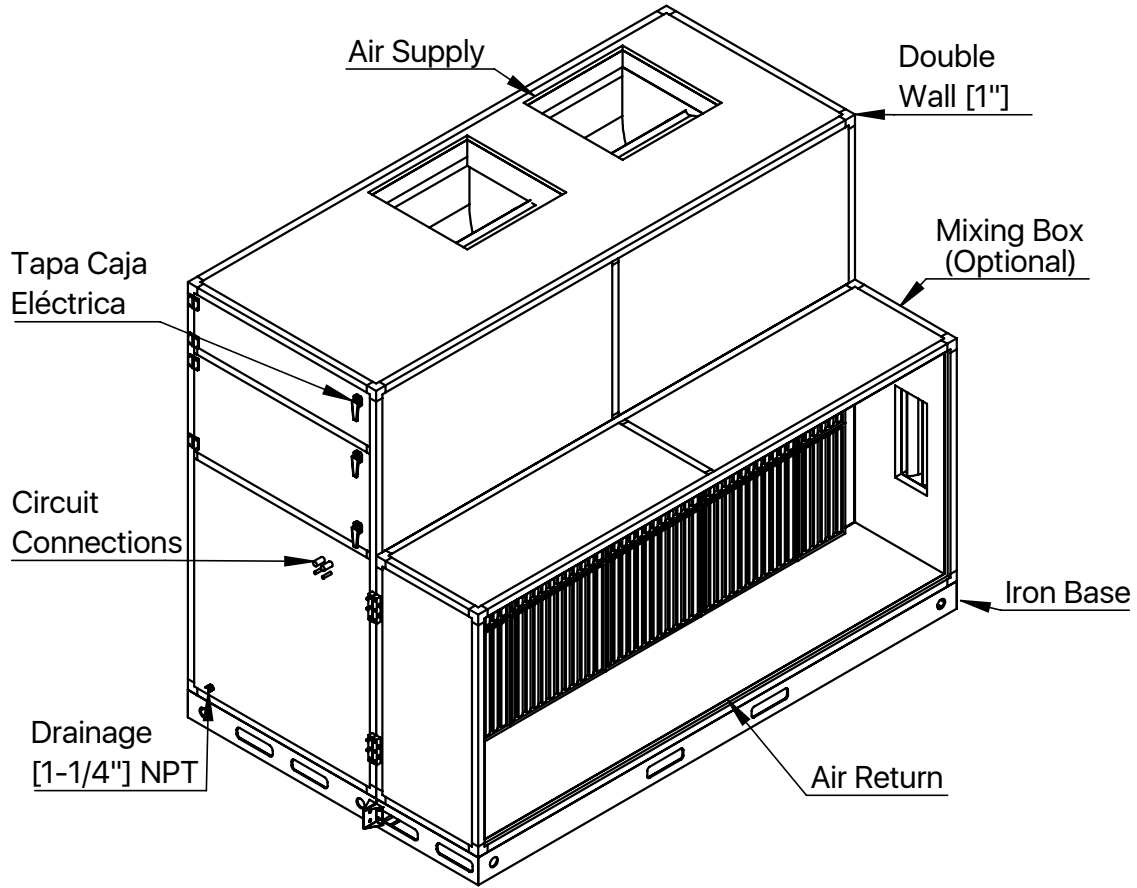

Top View

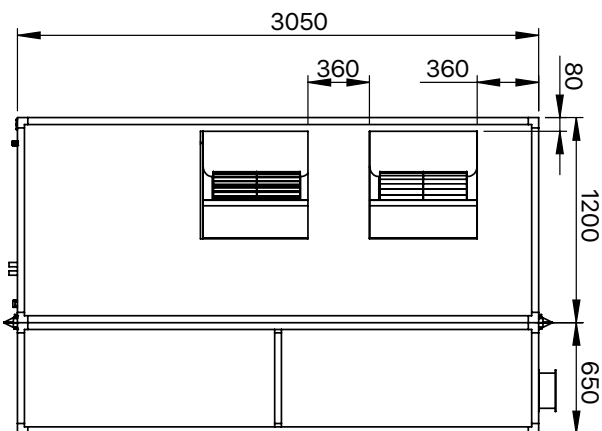

Frontal View

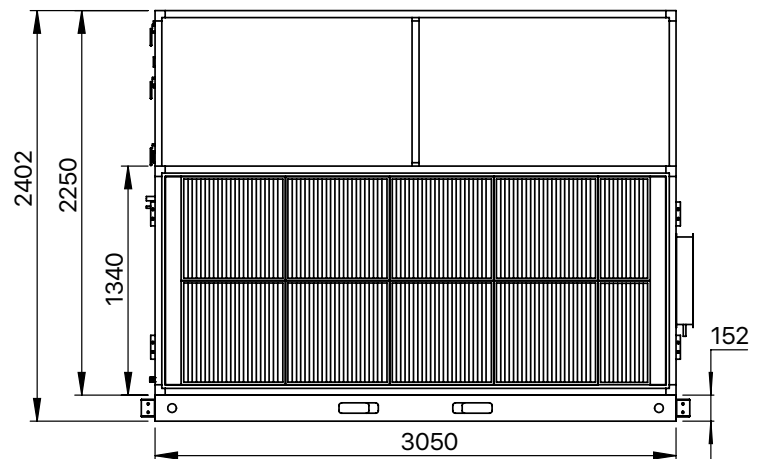

Note: All measurements are in millimeters (mm).

Safety Distance

The following minimum free spaces must be observed for the proper performance and capacity of the unit. It is very important that air outlets are not linked in the same duct before a minimum distance of 1.5 meters and preferably at a distance of 2 meters.

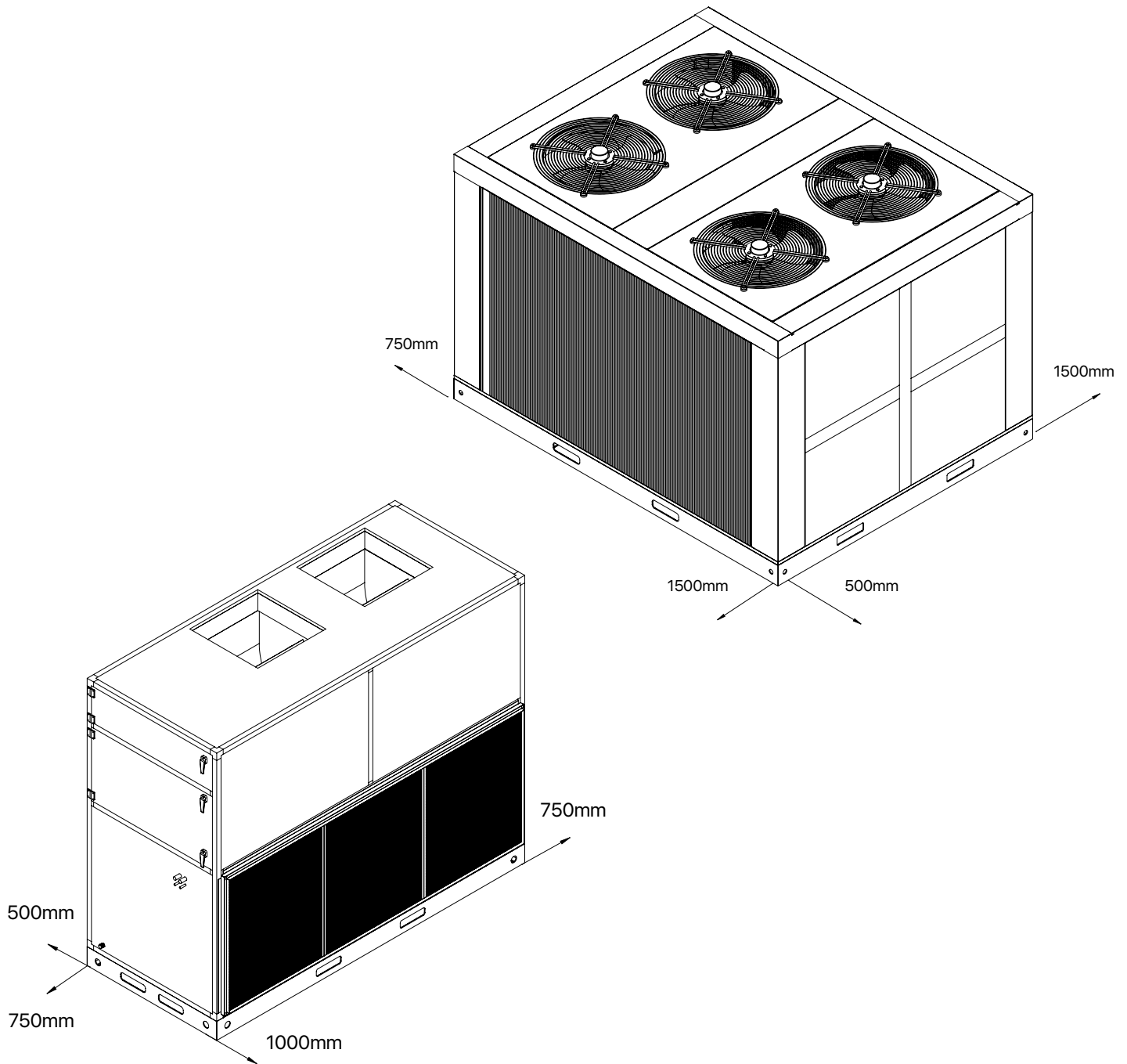

Safe Handling

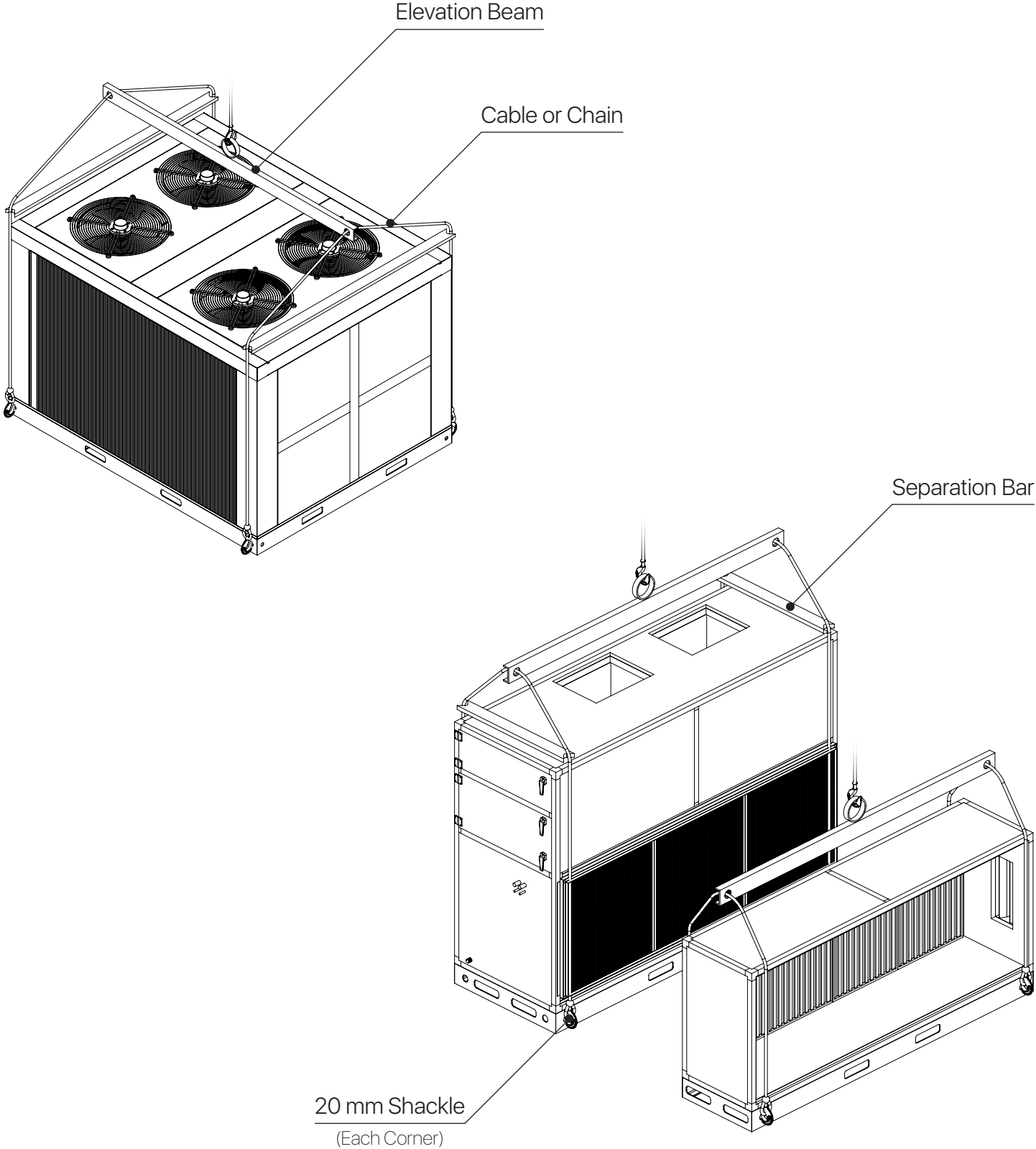

Electric Diagram

While performing the electrical installation, the authorized technician must verify that they are complying with the electrical circuit of the equipment shown below:

GLCK600DG4AB (208V-230V / 3PH / 60Hz) (POWER)

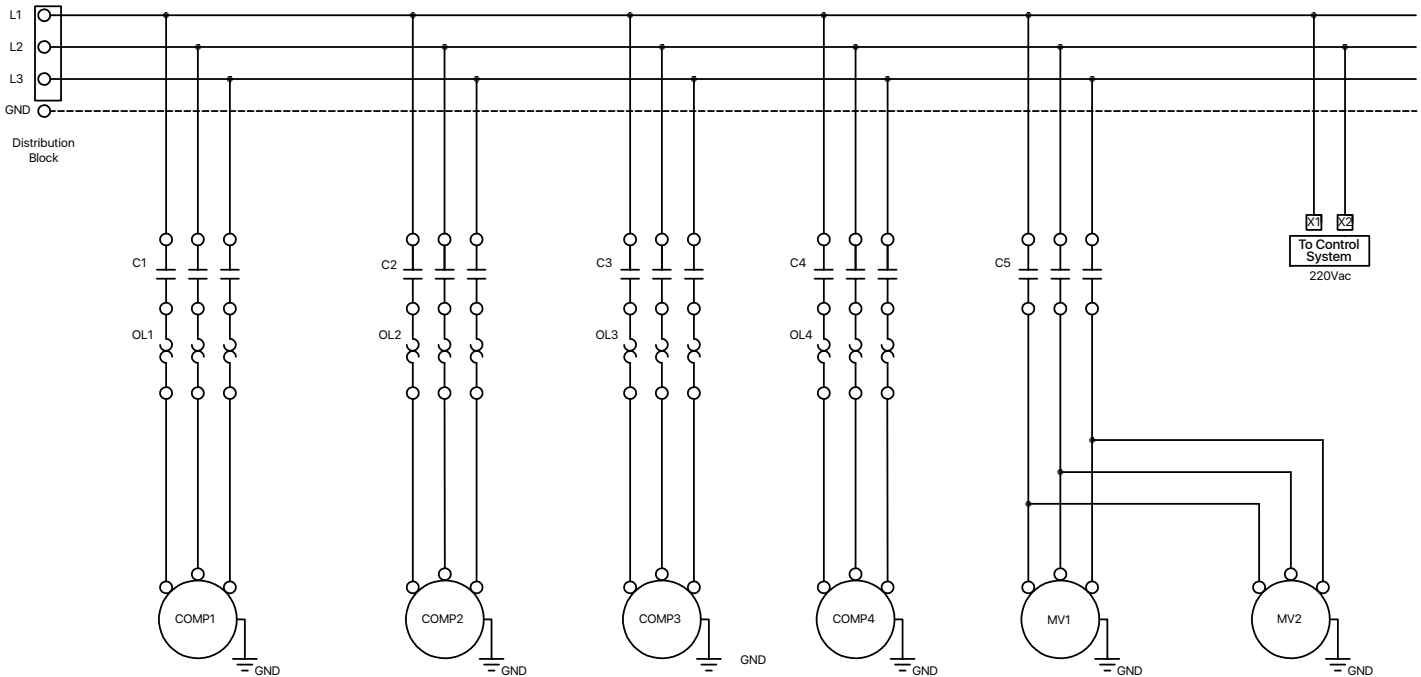

(CONTROL)

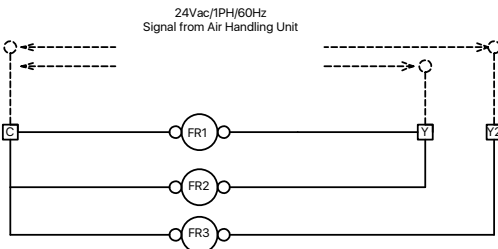

- When replacing any cable, make sure that the gauge and type of insulation is the same as the original.
- Use only copper conductors.

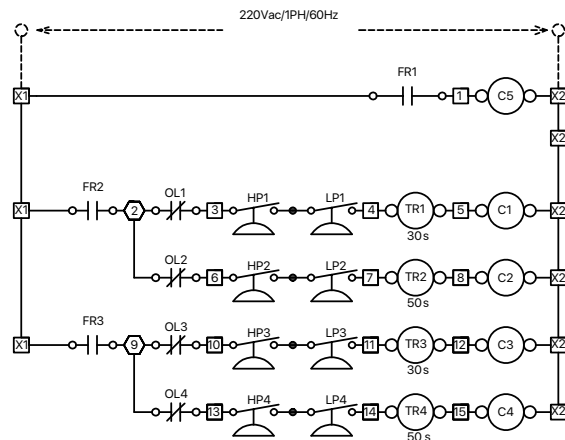

WARNING

High Voltage: Disconnect all supply source before manipulating this unit. Multiple energy sources can be present. Not doing so can cause property damage, personal injury or death.

Elements:

- COMP1/2: Compressor
- AF: Condenser Axial Fan
- L: AC Supply Lines
- C1-C6: Contactor
- OL: Thermal Relay
- TR: Temporizer
- LP: Low Pressure Switch
- HP: High Pressure Switch
- C: Common 24Vac Lines
- Y: Compressor Signal Stage 1
- Y2: Compressor Signal Stage 2

- Factory Wiring
- Field Wiring
- Terminal Block Connection
- Direct Connection to Component

Electric Diagram

While performing the electrical installation, the authorized technician must verify that they are complying with the electrical circuit of the equipment shown below:

GLCK600DG7AB (460V / 3PH / 60Hz) (POWER)

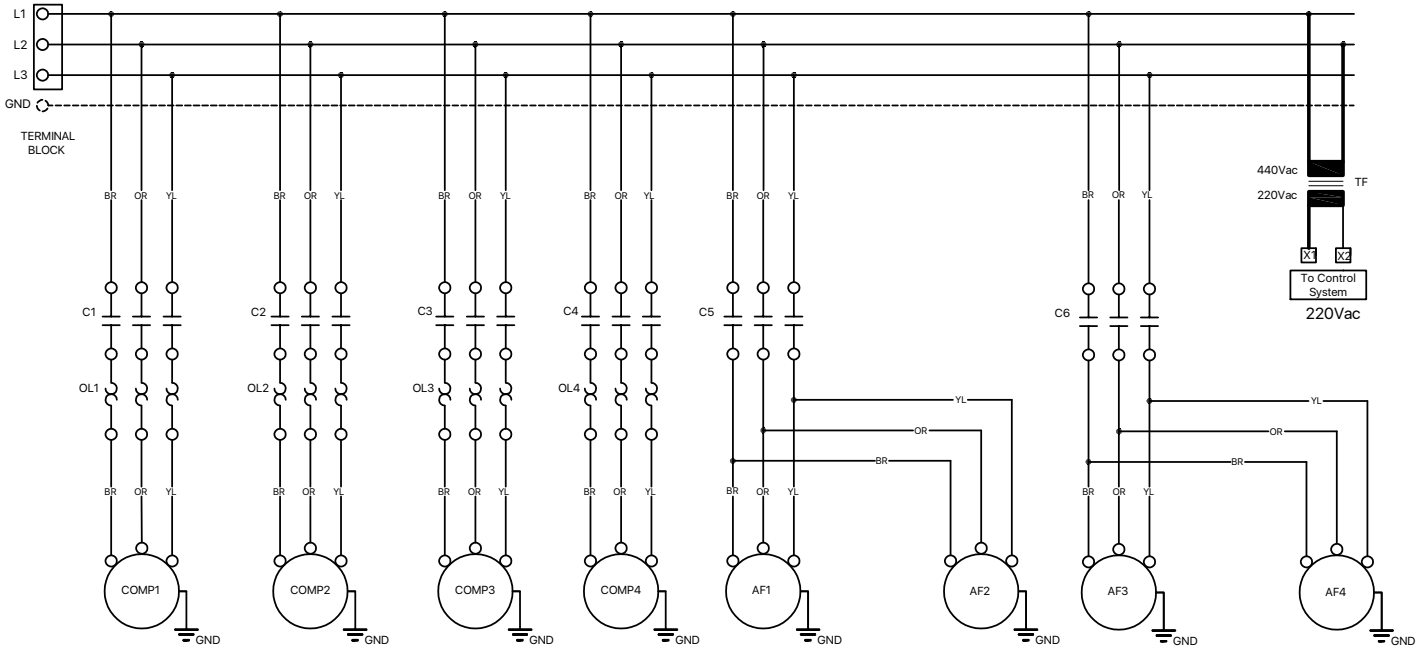

(CONTROL)

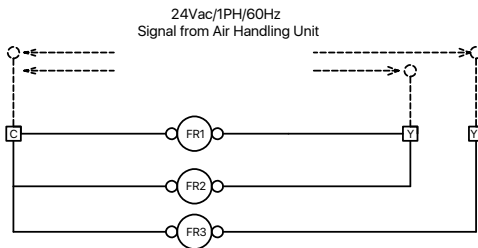

- When replacing any cable, make sure that the gauge and type of insulation is the same as the original.
- Use only copper conductors.

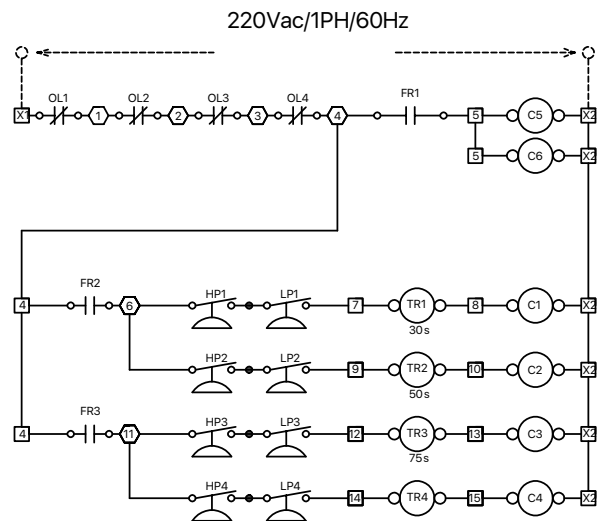



WARNING

High Voltage: Disconnect all supply source before manipulating this unit. Multiple energy sources can be present. Not doing so can cause property damage, personal injury or death.

Elements:

- COMP1/2: Compressor
- AF: Condenser Axial Fan
- L: AC Supply Lines
- C1-C6: Contactor
- OL: Thermal Relay
- TR: TempORIZER
- LP: Low Pressure Switch
- HP: High Pressure Switch
- C: Common 24Vac Lines
- Y: Compressor Signal Stage 1
- Y2: Compressor Signal Stage 2

- Factory Wiring
- - - Field Wiring
- Terminal Block Connection
- Direct Connection to Component

Electric Diagram

While performing the electrical installation, the authorized technician must verify that they are complying with the electrical circuit of the equipment shown below:

GLCK600DG9AB (380V / 3PH / 60Hz) (POWER)

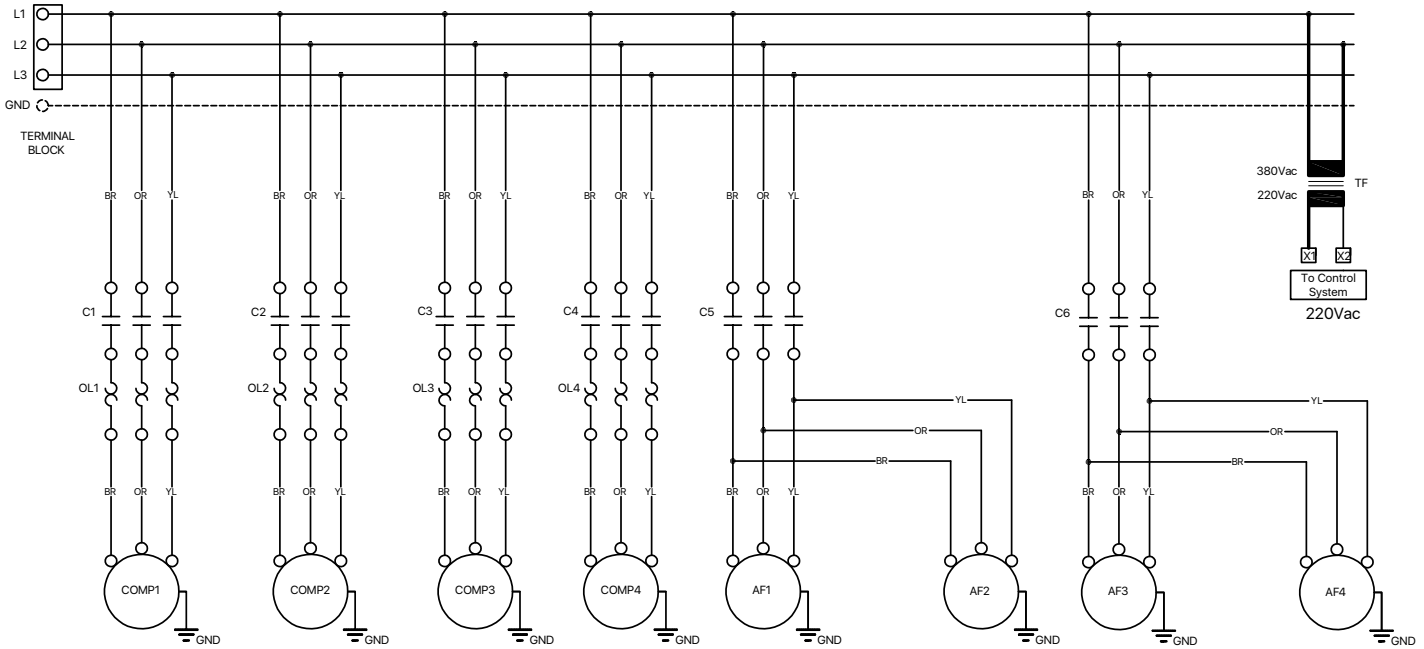

(CONTROL)

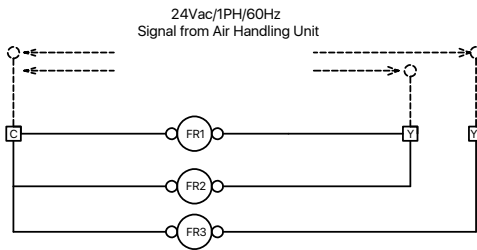

- When replacing any cable, make sure that the gauge and type of insulation is the same as the original.
- Use only copper conductors.

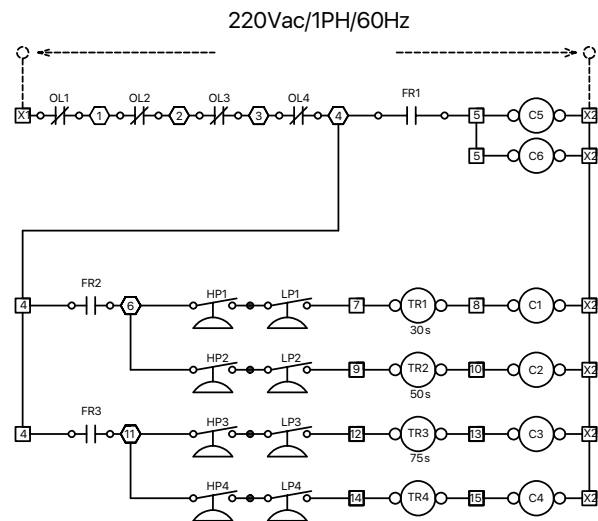



WARNING

High Voltage: Disconnect all supply source before manipulating this unit. Multiple energy sources can be present. Not doing so can cause property damage, personal injury or death.

Elements:

- COMP1/2: Compressor
- AF: Condenser Axial Fan
- L: AC Supply Lines
- C1-C6: Contactor
- OL: Thermal Relay
- TR: Temporizer
- LP: Low Pressure Switch
- HP: High Pressure Switch
- C: Common 24Vac Lines
- Y: Compressor Signal Stage 1
- Y2: Compressor Signal Stage 2

- Factory Wiring
- - - Field Wiring
- Terminal Block Connection
- Direct Connection to Component

Electric Diagram

While performing the electrical installation, the authorized technician must verify that they are complying with the electrical circuit of the equipment shown below:

GXBK600DG4BB (208V-230V / 3PH / 60Hz)

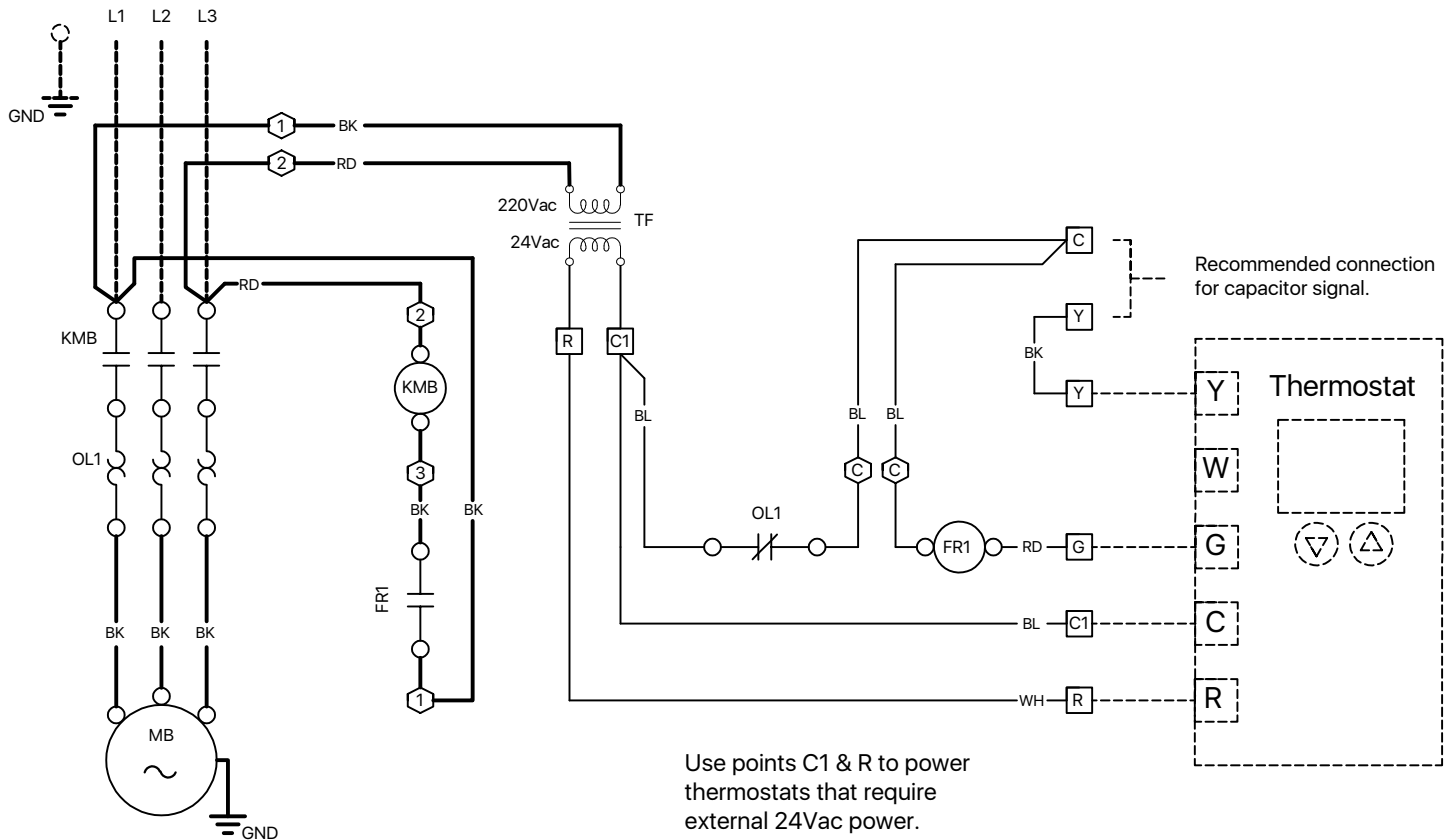

⚠ WARNING

High Voltage: Disconnect all supply source before manipulating this unit. Multiple energy sources can be present. Not doing so can cause property damage, personal injury or death.

Elements:

- MB: Blower Motor
- TF: Transformer
- L: AC Supply Lines
- FR: Auxiliary Relay
- G: Fan Signal
- Y: Condenser Signal
- R: 24VAC Common Line
- C1: 24VAC Auxiliary Line
- GND: Ground
- KMB: Blower Motor Contactor
- OL: Thermal relay
- C: Common Point

Color Codes:

- BK: Black
- BL: Blue
- BR: Brown
- OR: Orange
- RD: Red
- WH: White
- YL: Yellow
- GR: Green

Factory Wiring:

- High Voltage
- Low Voltage

Field Wiring:

- - - High Voltage
- - - Low Voltage

Electric Diagram

While performing the electrical installation, the authorized technician must verify that they are complying with the electrical circuit of the equipment shown below:

GXBK600DG7BB (460V / 3PH / 60Hz)

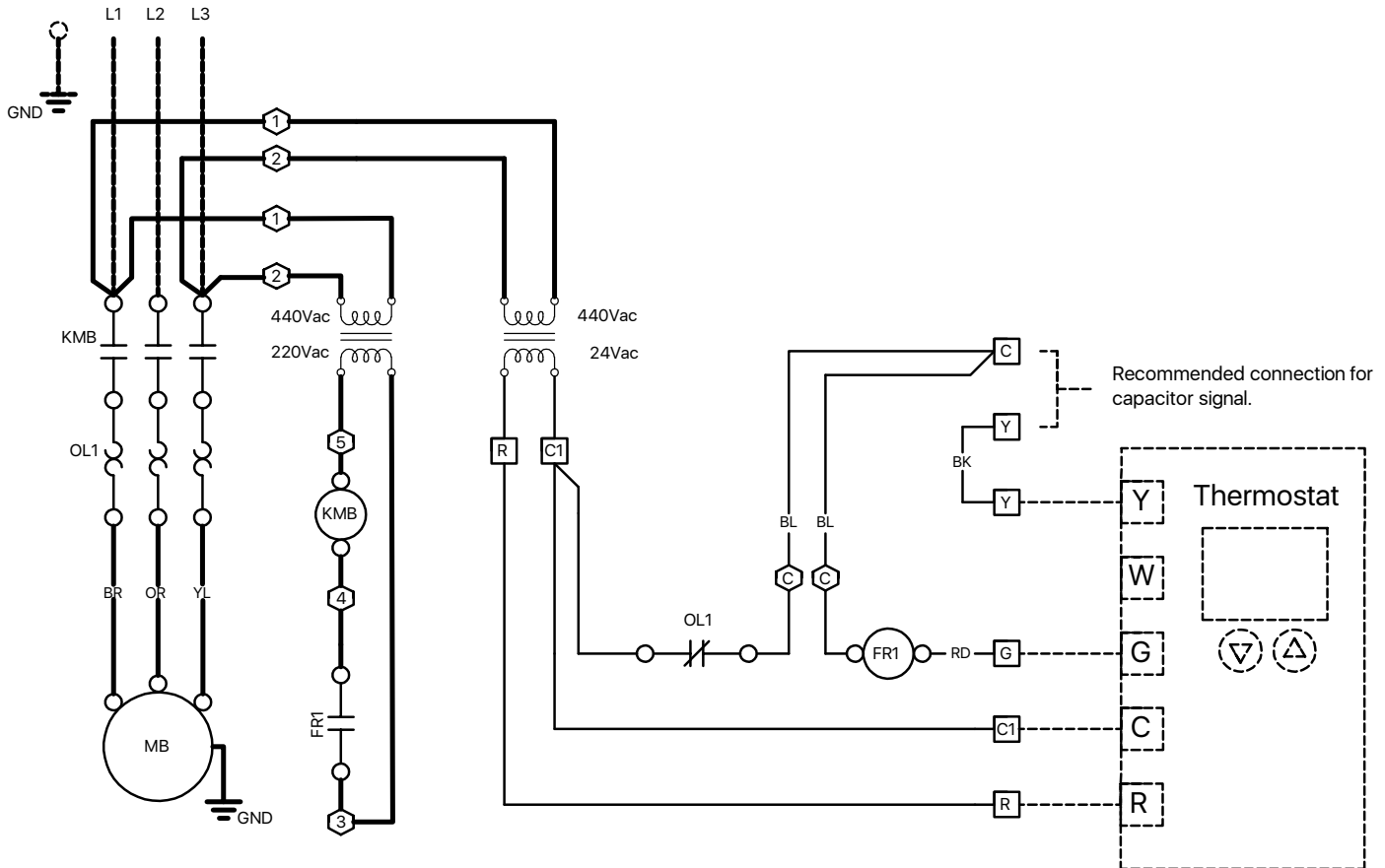

- When replacing any wire, make sure that the gauge and type of insulation is the same as the original.
- Use only copper conductors.

Use points C1 & R to power thermostats that require external 24 VAC.

WARNING

High Voltage: Disconnect all supply source before manipulating this unit. Multiple energy sources can be present. Not doing so can cause property damage, personal injury or death.

- Elements:**
- MB: Blower Motor
 - TF: Transformer
 - L: AC Supply Lines
 - FR: Auxiliary Relay
 - G: Fan Signal
 - Y: Condenser Signal
 - R: 24VAC Common Line
 - C1: 24VAC Auxiliary Line
 - GND: Ground
 - KMB: Blower Motor Contactor
 - OL: Thermal relay
 - C: Common Point

- Color Codes:**
- BK: Black
 - BL: Blue
 - BR: Brown
 - OR: Orange
 - RD: Red
 - WH: White
 - YL: Yellow
 - GR: Green

- Factory Wiring:**
- High Voltage
 - Low Voltage
- Field Wiring:**
- - - High Voltage
 - - - - Low Voltage

Electric Diagram

While performing the electrical installation, the authorized technician must verify that they are complying with the electrical circuit of the equipment shown below:

GXBK600DG9BB (380V / 3PH / 60Hz)

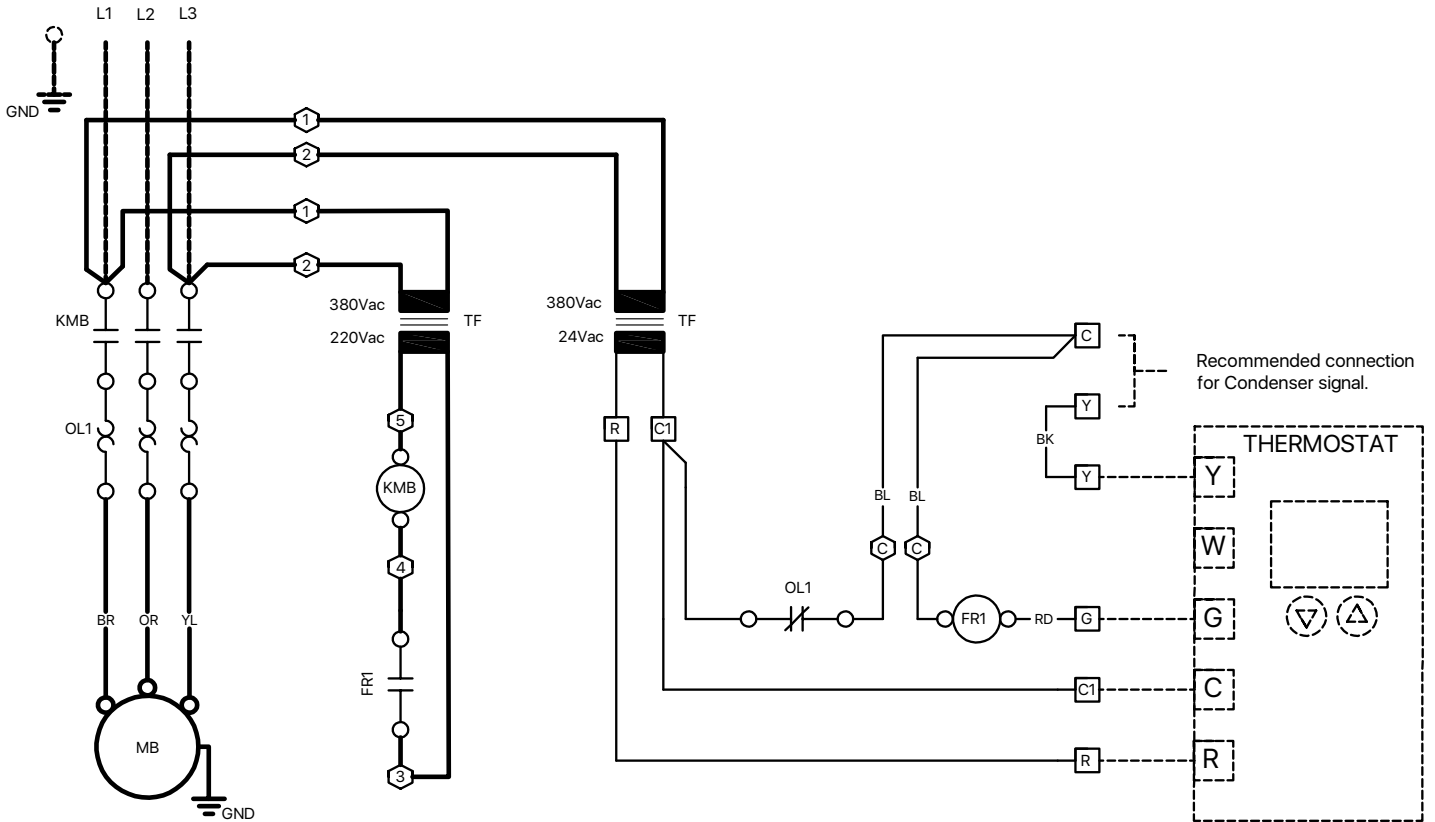

- When replacing any wire, make sure that the gauge and type of insulation is the same as the original.
- Use only copper conductors.

Use points C1 & R to power thermostats that require external 24 VAC.



WARNING

High Voltage: Disconnect all supply source before manipulating this unit. Multiple energy sources can be present. Not doing so can cause property damage, personal injury or death.

Elements:

- MB: Blower Motor
- TF: Transformer
- L: AC Supply Lines
- FR: Auxiliary Relay
- G: Fan Signal
- Y: Condenser Signal
- R: 24VAC Common Line
- C1: 24VAC Auxiliary Line
- GND: Ground
- KMB: Blower Motor Contactor
- OL: Thermal relay
- C: Common Point

Color Codes:

- BK: Black
- BL: Blue
- BR: Brown
- OR: Orange
- RD: Red
- WH: White
- YL: Yellow
- GR: Green

Factory Wiring:

- High Voltage
- Low Voltage

Field Wiring:

- High Voltage
- Low Voltage

Suggestions for Installation

The conditions that must be taken into account in general before installing the equipment:

The works on the units must be carried out only by professionals. Do not connect the power supply until all the work is finished.

Considerations to take into account

1. It is very important in direct transmission equipment that air outlets are not linked in the same duct before a minimum distance of 1.5 meters and preferably at a distance of 2 meters.
2. Make sure the suspension support is strong enough to support the weight of the unit.
3. Most of the equipment weight is located in the refrigerant condensation zone, take into account for the installation of the base where the equipment will rest.
4. Select a place for an easy drainage connection. It is important to install a drainage trap.
5. Be sure to install the equipment level to ensure proper operation of the unit.
6. Select a place far from gases or explosive or combustible materials.
7. Preview the necessary free spaces for maintenance and technical assistance services.
8. Verify that the model, options and tension, indicated in the characteristics plate are correct.
9. Verify that the energy supply meets the specifications that appear on the equipment plate.
10. All field wiring must be carried out by duly qualified personnel. The wiring must be adjusted to the applicable local regulations.
11. The recommended minimum refrigerant piping length is of 3 meters and maximum of 40 meters.
12. Follow the appropriate requirements that establish the National Electric Code on mass connections.
13. Visually inspect the exterior of the unit, including the ceiling, to detect possible signs of damage during transport.
14. Perform a visual verification of the internal components to identify whether there is transport damage, as soon as possible, after the reception of the unit.
15. Avoid obstructions in the supply and return of air so the inner air will circulate properly.

Suggestions for Installation

Fixing Equipment by Modules (Optional)

There is the possibility that the system has separate structures for installation in the field through modules. In these cases, special care is taken to ensure that the fixing mechanism sent is properly tightened to guarantee structural stability and avoid possible air leaks/infiltration into the system. Before installing the equipment, remember to verify the good condition of the insulation between the modules to be joined.

Fixing System Between Modules

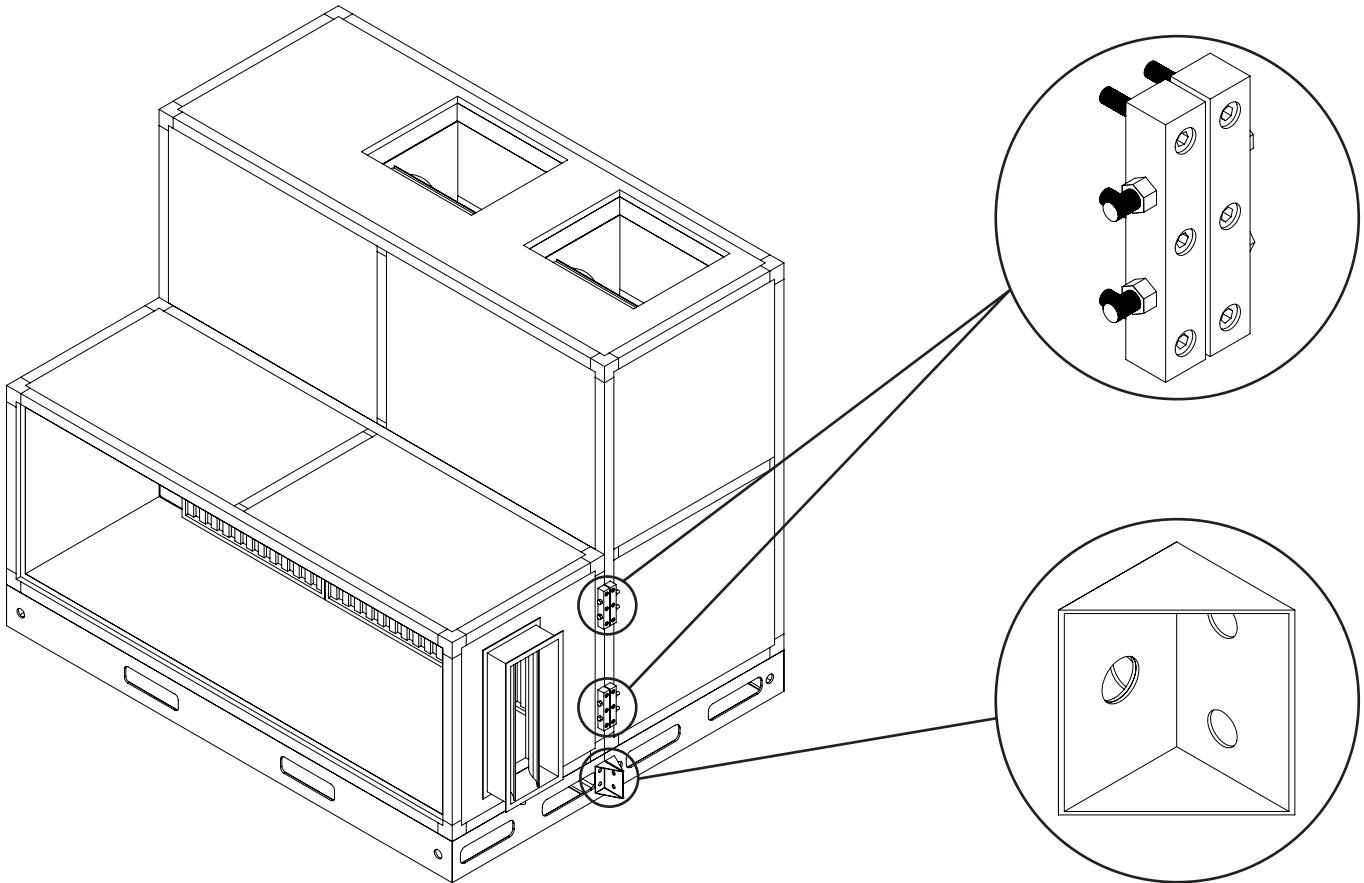

VERIFY

1. The unit must be installed level to ensure proper drainage.
2. There is no obstruction in the drain pan.
3. The equipment receives the electrical power established on the board.
4. All air ducts are well connected.
5. The air filters are properly attached and in good condition.
6. The air distribution system is within the pressure drop range established in the equipment design.

Suggestions for Ignition

Briefly, the steps for the ignition and commissioning of the equipment are as follows (only an authorized technician can do it):

Never do work without the help of professionals. Before making any connection, be sure not to have connected or energized the equipment or sources of equipment until all the work is finished.

Steps for ignition of the unit

1. From the breaker box, take electric power to the equipment. Verify that the capacity of the disjunct is the required to protect the equipment.
2. Connect lines to the power beams, indicated as L1 and L2 of the electric box or L1, L2 and L3 for three-phase equipment.
3. Confirm that the ground connection is reliable and that the ground cable is connected to the special device of the building. Never connect the ground cable with gas, water, telephone cables, etc.
4. From the equipment, wire the three control lines R, G, Y & O*, indicated in the electric box to the respective thermostat terminals.
5. The operation of the air conditioning system is controlled by the interior thermostat. You must adjust the thermostat to a set temperature (set point) to keep the interior temperature at the level you select.
6. The frequent thermostat movement produces faster cycles, which is potentially harmful to the compressor. For no reason move the thermostat temperature selector for at least 5 minutes after the compressor has turned off.
7. Ensure that all connections are correctly made, subject and according to the electrical diagrams provided.
8. Action switches (installed in the field) to energize the equipment.
9. Supply sufficient electrical capacity and respect the electrical cable section necessary for specified consumption.

Maintenance Recommendations

With due maintenance and care, the air conditioning unit will work successfully. Before maintaining, consider the following security precautions:

WARNING!

To prevent damage to the equipment and personal injury or death, disconnect all electricity supply to the equipment before removing access panels to perform some maintenance work. Disconnect electricity to the interior and exterior units.

NOTE: It is possible that there is more than one electric disconnection switch.

WARNING!

Although special care has been taken to minimize acute edges in the construction of your equipment, be extremely careful when handling the pieces or putting your hand inside it.

Recommendations

1. Clean the air filter carefully, this in order to avoid a restricted air flow, which decreases the efficiency of the unit and its useful life.
2. Check the status of the evaporator coil. It is ideal that there is no obstruction, in order to guarantee the free flow of the coil.
3. In case it is necessary to clean the coil, you can do it with a detergent solution and rinse it with water. This may require coil extraction. Be careful not to fold or damage the fins.
4. Do not allow waste to accumulate around the unit or above it.
5. Periodically inspect the equipment power. Make sure to have the necessary power for the operation of this. The current of the main components of the system must be monitored according to the equipment plate.
6. Periodically inspect work pressures in the system (high and low pressure). They should not exceed their operation rank in normal use conditions.
7. It is recommended to verify parameters such as overheating and refrigerant overcooling. Which under normal conditions of use will have values between 8 and 15 ° F for overheating, and values between 5 and 15 ° F in overcooling.
8. Periodically review the condenser fan status to avoid dirt or friction between sheets that can unbalance the fans.
9. Periodically review that there is no obstruction in the equipment drainage to avoid overflowing water from the equipment.



In accordance with its continuous progress policy and product improvement, Goodman reserves the right to make changes without prior notice.