

# STEALTH

## ALL IN ONE SOLAR LIGHT



2020 EXTERIOR LUMINAIRE OF THE YEAR



**ALL-IN-ONE**  
standalone design

**50W (max)**

187 lm/W (max)

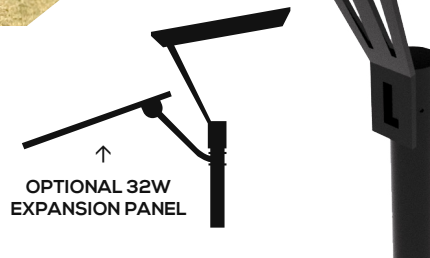

Designed in Australia, the GFS-STEALTH is a high performance, all in one solar light. Heavy duty die-cast aluminium construction with tough marine grade powder coating and stainless steel fixtures ensures reliable performance in the harshest environments.

The elegant design offers a solar powered alternative to conventional hard-wired lighting in a sleek, ultra-modern package.

IoT Ready – the unit is fully compatible with the SAM Solar Monitoring software platform.

### APPLICATIONS

- Coastal
- Marine / Jetties
- Pathways
- Small Car Parks
- Recreation Areas

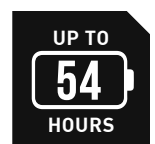

**MODEL****GFS-STEALTH5-4K****GEN5**

Power	50W (max)
Lumens	187 lm/W (max)
CCT	4000K
LED	CREE X-PG
Lens	LEDIL T3 type 135° x 85° / IK-10 rated
PIR Boost Power	21W - On until 30 seconds post movement
PIR Detection Range	6-8m (360° detection zone)
Solar Panel	65W(p) N type monocrystalline military grade with USA Made Solar Cells and edgeless frame design (Additional 32W panel is available as an option)
Solar Input Port (DC)	Expansion port for optional additional solar panel
Battery Capacity	12.8v / 36Ah / 460.8Wh
Battery Type	LiFePo <sub>4</sub> with passive cell balancing technology
Autonomy	54 hours (4.5 nights)* Advanced Power Scaling (APS) can extend autonomy to 100hrs +
Charge Controller	MPPT type with temperature and short circuit protection. Programmable custom settings.
Operating Temp.	-20°C to 60°C
Material	Die-cast Aluminium with TIGER Drylac® marine grade powder coating & stainless fixtures
Mounting	Pole Mount Bracket: 62mm ID Tennon – 7° fixed angle Wall Mount Bracket: 7° fixed angle
Mounting Height	4-8m (6m typical, foundation Ø350 x 1000mm)
Sail Area / EPA	0.1146m <sup>2</sup>
Product Dimensions	540L x 540W x 66H (mm)
Product Weight	Light Fixture: 17.2kg Pole Mount Bracket: 4.5 kg Wall Mount Bracket: 6 kg
Package Dimensions	Light Fixture: 620mm x 620mm x 182mm Pole Mount Bracket: 590 x 260 x 200mm Wall Mount Bracket: 590 x 260 x 100mm
Package Weight	Light Fixture: 21.25 kg Pole Mount Bracket: 5.65 kg Wall Mount Bracket: 6 kg
Warranty	5 year / 25 year solar panel / 10 year battery**
Operating Profile	Automatic dusk to dawn
Profile Options	1 Default operation – First 5 hours at 15W (+ 21W PIR Boost = 36W) Remainder of night at 5W (+ 21W PIR Boost = 26W) PIR Boost activates on motion detection. Remains activated until 30 sec. of no movement 2 Constant light level all night 3 Constant light level all night plus PIR Boost 4 Custom – Contact us to determine optimum settings for specific application / location

\*\*Full warranty details are available at:  
<https://greenfrogssystem.com.au/product-warranty>

## OPTIONS

---

GFS-6MBHG	6m base hinge pole w/1m foundation (hot dipped galvanised)
GFS-6MBHB	6m base hinge pole w/1m foundation (black powder coated)
GFS-6MKJB	6m direct bury pole no foundation (black powder coated)
GFS-STE-PMB7	Pole mount bracket - 60mm spigot
GFS-STE-WMB7	Wall mount bracket - 10mm gauge steel
GFS-PM60-76	Spigot adaptor (reducer) - 76mm > 60mm
GFS-STE-BOSS	Boss kit adaptor - Required for mounting 2 / 3 / 4 fixtures on single pole (requires wall mount brackets)
GFS-32-EXP	Additional 32W solar panel - 645 x 340 x 30mm (includes pole mount bracket)
GFS-STE-20113-5PM	T5 Lens
GFS-STE-3K-CCT	3000K CCT
GFS-STE-TUR-CCT	Turtle CCT
CALL	SAM IoT SMART city monitoring and control system

## CERTIFICATIONS

---

UL Certification (USA)	UL8750 / UL1598
UL Certification (Canada)	CAN/CSA-C22.2 No250.0-18
Salt Spray Resistance	ASTM B117, ISO-9227
IES / CIE modelling files	America Accreditation Body under ILAC MRA agreement (USA) / NATA (AUSTRALIA)

## MULTI-UNIT MOUNTING

---

**TWIN**

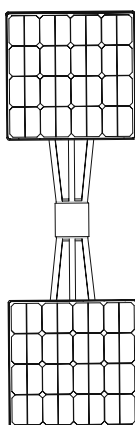

**TRIPLE**

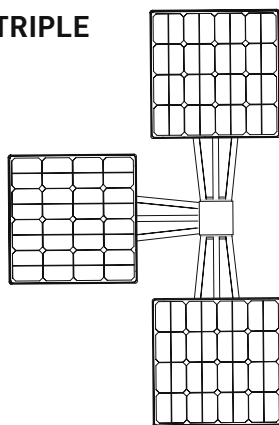

**QUAD**

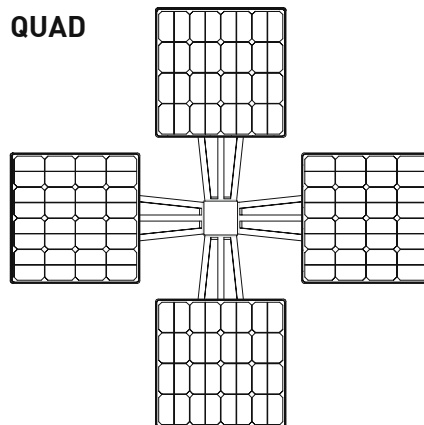

# PRODUCT DIMENSIONS

## POLE MOUNT

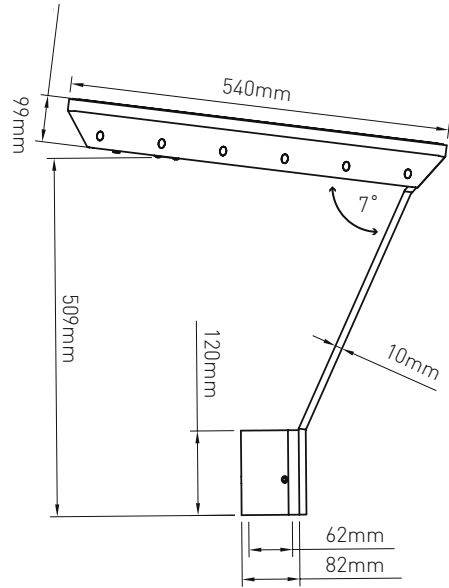
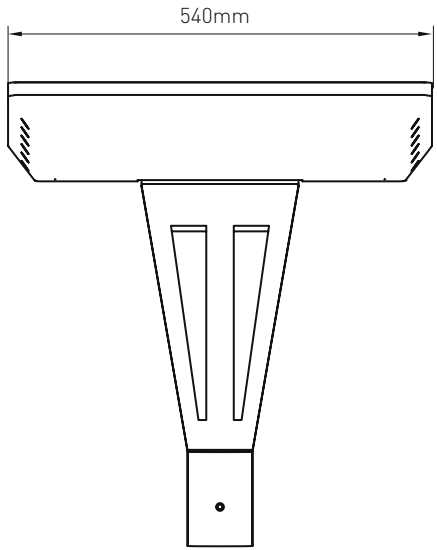

## WALL MOUNT

