

# GFS-200-KT GEN 1

## SOLAR STREET LIGHT KIT



**FITS EXISTING POLES**



**30W / 60W / 75W**

5,610lm / 11,220lm / 14,025lm

The GFS-200-KT is designed to be mounted onto an existing pole and replace mains powered street lighting offering an environmentally friendly, off-grid solution where traditional lighting has failed or is too costly to repair.

It has the same hardware as the GFS-200 (without the pole) and offers a reliable, vandal resistant solution that can be installed anywhere requiring reliability and performance without the costs of grid connection or energy supply.

### APPLICATIONS

- Streets
- Minor Roads
- Pathways
- Car Parks
- Industrial
- Commercial
- Marinas / Jetties
- Parks / Recreation



# GFS-200-KT SOLAR STREET LIGHT KIT



## SPECIFICATIONS

<b>MODEL</b>	<b>GFS-200-KT</b>
--------------	-------------------

## OPERATING PROFILE / OPERATION MODES

Standard 30W - **All night operation** - Unit operates at 100% (5610lm) until dawn.  
 Standard 60W - **100% for 6 hours** - Unit operates at (11220lm) then dims to 15W until dawn  
 Standard 75W - **100% for 4 hours** - Unit operates at (14025lm) then dims to 15W until dawn  
**NOTE:** Configurable TIMER settings for ON / OFF / DIM are available upon request.

## LED

Type	CREE XP-G LED
Watts (Light Output)	30W (standard)   60W (optional)   75W (optional)
Lumens	5,610lm   11,229lm   14,025lm
CCT (Colour Temperature)	4000K (standard) / 3000K (optional)
Optics	T3 (Standard) 135° x 85°   T5 (Optional) 110° x 135°

## BATTERY

Autonomy	60 hours (5 nights)*
Battery Type / Capacity	2 x 12v 110Ah (2640Wh) Sealed GEL AGM Batteries

## SOLAR PANEL

Watts (p) / Type	227W Monocrystalline
Efficiency	21%

## UNIT

Package Dimensions	Crate: 1650 x 880 x 560 mm / 65" x 35" x 22"
Package Weight	Crate: 169 kg / 372.5 lb
Product Weight	Complete Kit: 119 KG / 262.3 lb
Sail Area / EPA	0.536m <sup>2</sup> / 5.78 FT <sup>2</sup> @ 22° (FIXED)

## ENVIRONMENTAL

Operating Temp. Range	-20°C to 60°C / -4°F to 140°F
IP Rating	IP65 construction with IP68 waterproof connectors

## WARRANTY

Warranty Period	5 years (Unit) / 25 years (Solar Panel)**
-----------------	---

## OPTIONS

PROTECTION	Solar panel stone guard
	LED lens stone guard
	Anti-climbing spike collar
	Light spill shield front / back
	Goose neck outrigger extension
TWIN HEAD LED OPTION	Twin head 4K CCT / 180° / 90° configuration
	Twin head 3K CCT / 180° / 90° configuration
MOUNTING / FOUNDATION	Hinged base plate (lift + lower pole without crane)
	High wind footing cage (Aust region C / D)
BATTERY BOX OPTIONS	Battery box, grey powder coated
	Battery box, stainless steel 316
	Vandal resistant battery box upgrade kit
	In-ground pit box with galvanised lock lid

\*Based on fully charged battery at 30W / \*\*full warranty information is available at >> [greenfrogssystems.com.au/warranty](http://greenfrogssystems.com.au/warranty)

# GFS-200-KT SOLAR STREET LIGHT KIT



## PRODUCT DIMENSIONS

### KIT CONTENTS INCLUDE :

1. Instruction Manual
2. Serial Number Plate
3. Wooden Packing Crate
  - Solar Panel Assembly
  - LED Light
  - Light Arm
  - Light Cable Extension
  - Bird Guard
  - Batteries (x2)
  - Solar Controller

The GFS-200-KT can be installed without requiring a certified electrician as all circuits are low voltage

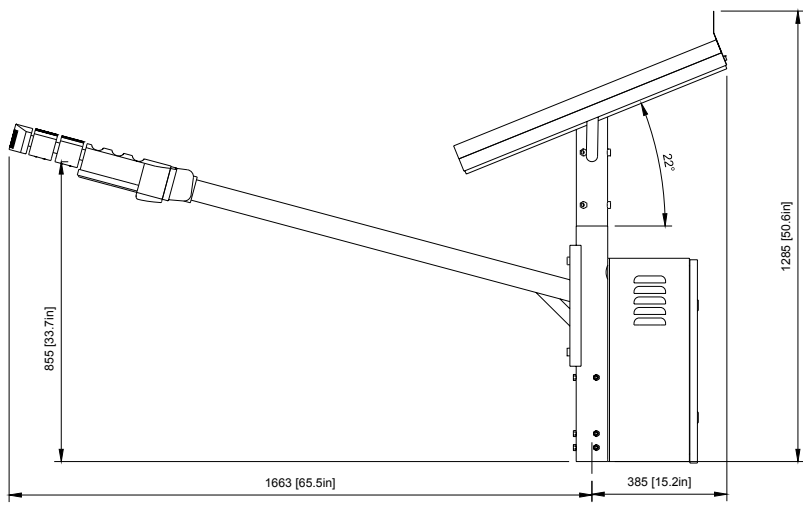
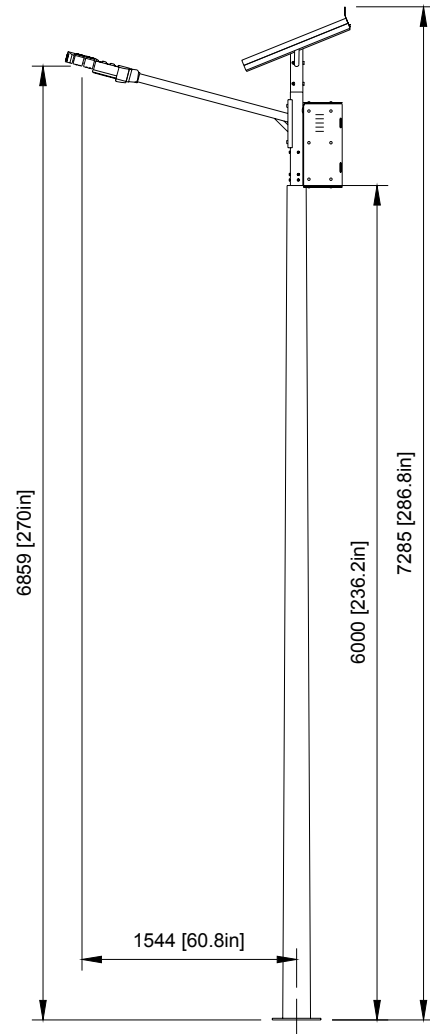
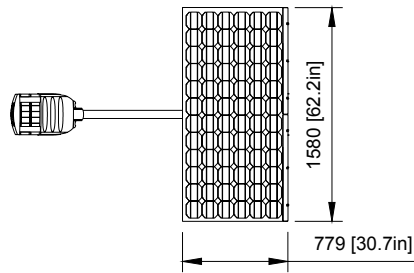

A (1:4)

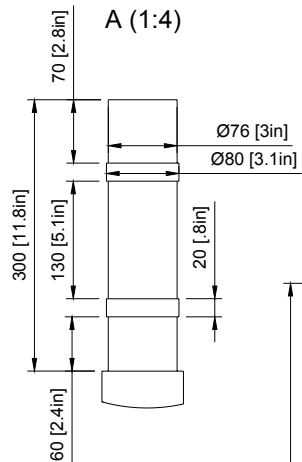
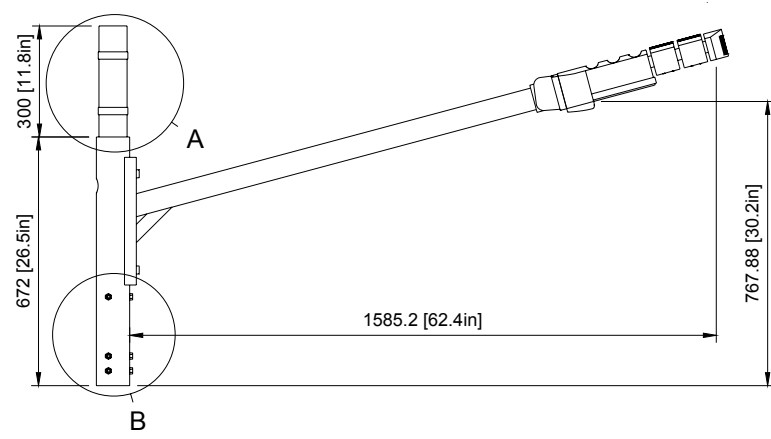

B (1:4)

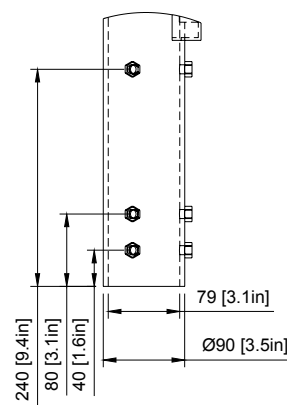

## MOUNTING OPTIONS

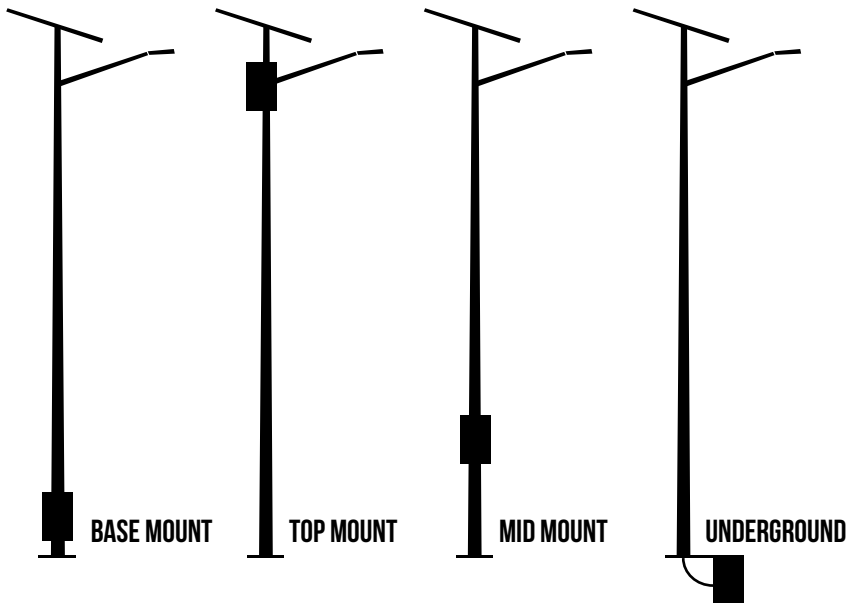

## PHOTOMETRICS

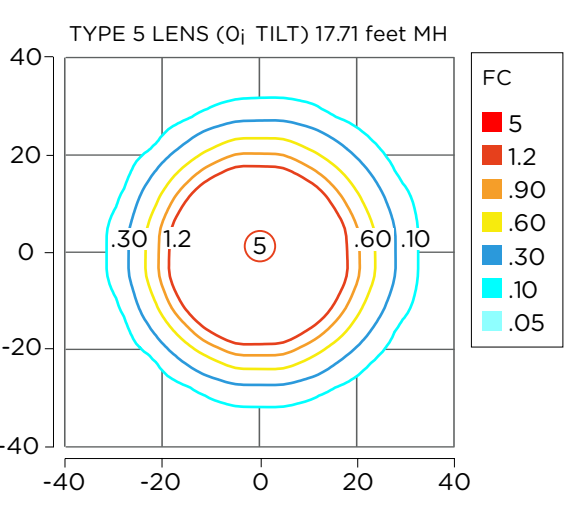
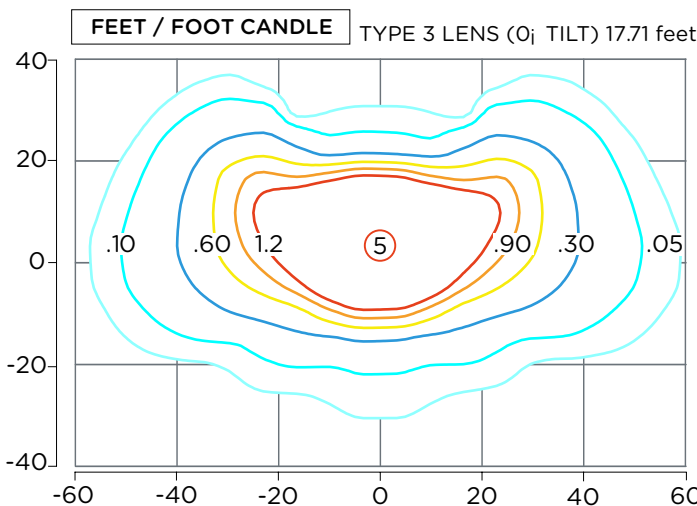
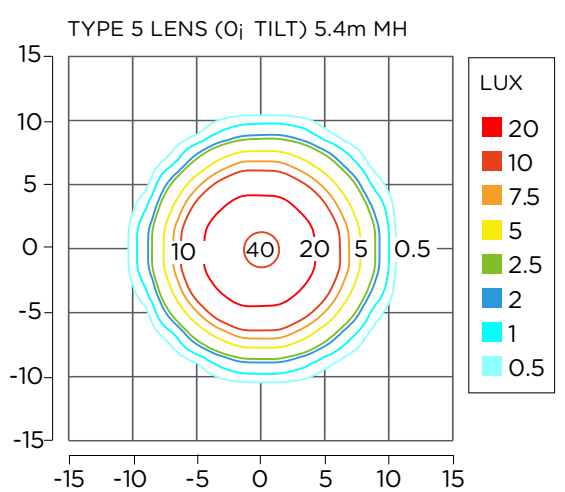
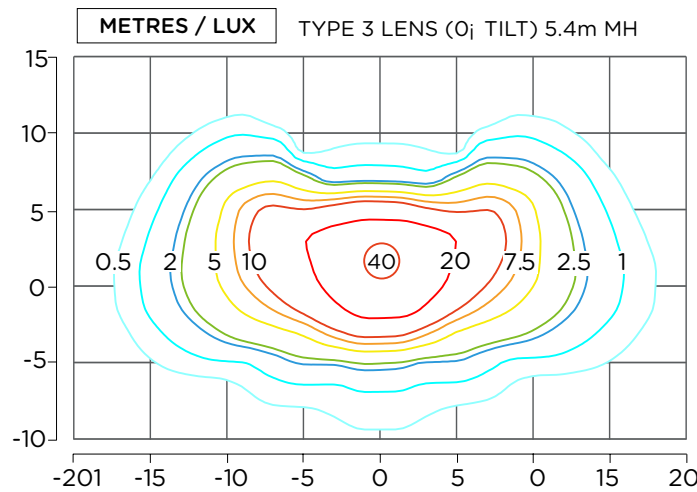

# GFS-200-KT SOLAR STREET LIGHT KIT



## LIGHT DISTRIBUTION

### FRONT VIEW

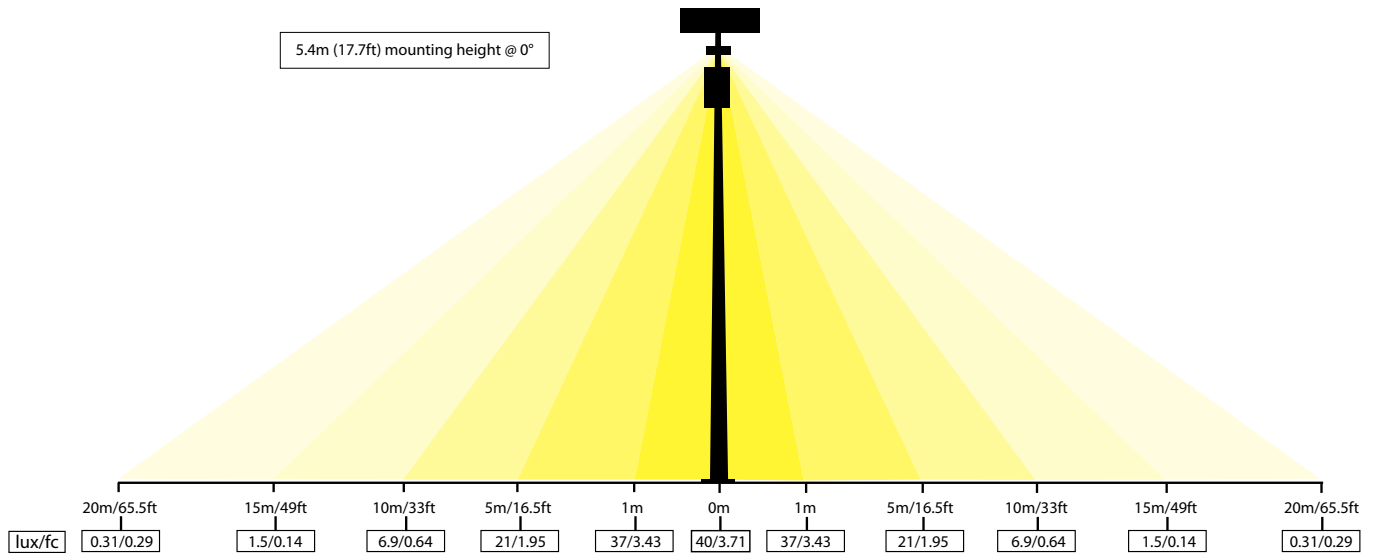

### SIDE VIEW

